

ANLI

Reversible heat pumps inverter

Cooling capacity 28,9 kW
Heating capacity 31,5 kW

- Version with built-in hydronic kit inverter
- High efficiency even at part load
- Production of hot domestic water (D.H.W.)



EUROVENT LCP

DESCRIPTION

Reversible Heat pumps units

VERSION

- ANLI_H** standard
- ANLI_HX** with inverter pump
- ANLI_HP** with on/off pump

OPERATIONAL LIMITS

Max. external air temperature 42°C, max. leaving water temperature 60°C

- *For more details on operating limits, refer to the technical documentation*
- Capable of variable water flow rates on primary circuit (terminals with 2-way valves)
- Perfect water temperature control even in systems with low water content
- Suitable for heat pump mode summer operation to provide domestic hot water (DHW) with the DCPX fan speed controller accessory (when provided)
- High efficiency scroll and Twin rotary compressors with permanent magnet DC motors of "high side" type (with high pressure casing), designed for variable speed operation
- Inverter pumps variable speed pump with water side pressure transducer installed and unit mounted microprocessor, capable of controlling various operating modes:
 - Constant ΔP : maintains constant pressure differential between pump inlet and outlet; pump speed reduces as terminal valves close
 - Variable ΔP : reduces pressure differential with flow reduction, in consideration of the pressure reduction in the pipe-work system to the terminals (recommended for larger pipe-work systems)
- Water filter, differential pressure switch, depending on the model, fitted on all units.
- High efficiency heat exchangers with trace heating as standard
- Axial flow fan units for extremely quiet operation
- Fitted with EMC filters

The built-in hydraulic kit includes

- Expansion vessel
- Safety valve water side
- Air vent valve

CONTROLLER

- Aermec Modu_Control circuit board
 - User interface with 6 soft-touch keys, 4 digit display, 6 LEDs
 - Control of the leaving water temperature with PID algorithm
 - Set-point compensation based on the external air temperature
 - Display of operating frequency
 - Control of compressor ramp speed
 - Auto-adaptive intelligent defrosting
 - Condensing control in summer with a 0-10 V modulating signal based on pressure and compensated for external air temperature (with DCPX accessory (when provided))
 - Load limiting safety control by reducing compressor speed
 - High and low pressure transducers
 - Automatic reset of alarms before tripping
 - Alarms history

ACCESSORIES

MODU-485BL: RS-485 interface for supervising systems with MODBUS protocol.

AERSET: accessory allows the automatic compensation of the operating set point of the unit to which it is connected, based on a 0-10V MODBUS input signal. **Mandatory accessory: MODU-485BL**

MULTICONTROL: Allows the simultaneous control of several chillers or heat pumps (up to 4) fitted with our MODUCONTROL controller and installed in the same hydraulic system. For complete control the following accessories are available:

SPLW: System water temperature sensor. In most cases the loose supplied sensors for each chiller/heat pump are sufficient. In cases of a common flow/return header this sensor can be used to control the common system supply water temperature for the chillers connected to the header, or it can be used for temperature monitoring.

SDHW: Domestic hot water temperature sensor. Used with the storage tank to control the temperature of water produced. **VMF-CRP to predict accessory for the management of the probes SPLW / SDHW if provided with the MULTICONTROL**

PR3: Simplified remote panel. Allows to perform the basic controls of the unit with alarm signals. It can be controlled with a shielded cable at a distance up to 150 m.

DCPX: Allows correct operation, in cooling mode, with outside temperatures lower than 20 °C and as low as – 10 °C, in heating mode up to 42 °C.

BSKW: Electric heater kit with IP44 panel for remote mounting in a sheltered area. Available in single and three phase power supply:

— BS6KW400T (6 kW, 400V/3/50Hz)

— BS9KW400T (9 kW, 400V/3/50Hz)

VT: Anti-vibration mounts.

SAF: Thermal accumulator for the instantaneous production of domestic hot water. **Refer to the dedicated "SAF" card for more information necessary for the correct operation of the system, as well as details on the required or recommended accessories. Please consult the VMF system for the production of DHW with Thermal Accumulator not supplied by Aermec.**

ACCESSORIES FACTORY FITTED ONLY

KR: Electric anti-freeze resistance for plate heat exchanger.

KRB: Electric anti-freeze resistance kit for base; prevents the formation of ice on the base.

COMPATIBILITY WITH VMF SYSTEM

For further information on system, refer to specific documentation.

ACCESSORIES COMPATIBILITY

Size	Version	Power supply	101
MODU-485BL	all		•
AERSET	all		•
MULTICONTROL	all		•
SPLW	all		•
SDHW	all		•
VMF-CRP	all		•
PR3	all		•
BS6KW400T		400V/3N	•
BS9KW400T		400V/3N	•
SAF	all		•

Condensation control temperature

Version	101
all	DCPX53

Antivibration

Version	101
all	VT15

Electric anti-freeze resistance for exchanger

Version	101
all	KR100

A grey background indicates the accessories assembled in the factory

Electric anti-freeze resistance kit for base

Version	101
all	KRB3

A grey background indicates the accessories assembled in the factory

CONFIGURATOR

Field	Description
1,2,3,4	ANLI
5,6,7	Size 101
8	Model H Heat pump
9	Version ° Standard X With inverter pump P With on/off pump
10	Heat recovery ° Without heat recovery

Field	Description
11	Coil ° Aluminium R Copper S Tinned copper V In painted aluminium-copper (epoxy paint)
12	Operating field ° Electronic expansion valve (leaving water temperature down to 4°C) contact head office for lower temperatures
13	Evaporator ° Standard
14	Power supply T 400V/3N/50Hz

TECHNICAL DATA

ANLI - H

Size	101	
Cooling performance 12 °C / 7 °C (1)		
Cooling capacity	kW	28,9
Input power	kW	11,7
Cooling total input current	A	16
EER		2,48
Water flow rate system side	l/h	4985
Pressure drop system side	kPa	50
Heating performance 40 °C / 45 °C (2)		
Heating capacity	kW	31,5
Input power	kW	11,3
Heating total input current	A	16
COP		2,78
Water flow rate system side	l/h	5457
Pressure drop system side	kPa	59
Cooling performance 23 °C / 18 °C (3)		
Cooling capacity	kW	42,0
Input power	kW	13,7
EER		3,08
Water flow rate system side	l/h	7301
Pressure drop system side	kPa	107
Heating performance 30 °C / 35 °C (4)		
Heating capacity	kW	33,4
Input power	kW	9,7
Heating total input current	A	13
COP		3,43
Water flow rate system side	l/h	5762
Pressure drop system side	kPa	66

(1) Data 14511:2018; System side water heat exchanger 12 °C/7 °C; External air 35 °C

(2) Data 14511:2018; System side water heat exchanger 40 °C/ 45 °C; Outside air 7 °C d.b. / 6 °C w.b.

(3) Data 14511:2018; System side water heat exchanger 23 °C/ 18 °C; External air 35 °C

(4) Data 14511:2018; System side water heat exchanger 30 °C/ 35 °C; Outside air 7 °C d.b. / 6 °C w.b.

ANLI - HX-HP

Size	101	
Cooling performance 12 °C / 7 °C (1)		
Cooling capacity	kW	29,3
Input power	kW	11,9
Cooling total input current	A	18
EER		2,47
Water flow rate system side	l/h	4985
Pressure drop system side	kPa	175
Heating performance 40 °C / 45 °C (2)		
Heating capacity	kW	31,2
Input power	kW	11,5
Heating total input current	A	17
COP		2,70
Water flow rate system side	l/h	5457
Pressure drop system side	kPa	158
Cooling performance 23 °C / 18 °C (3)		
Cooling capacity	kW	42,6
Input power	kW	13,8
EER		3,08
Water flow rate system side	l/h	7301
Pressure drop system side	kPa	81
Heating performance 30 °C / 35 °C (4)		
Heating capacity	kW	33,0
Input power	kW	9,9
Heating total input current	A	15
COP		3,33
Water flow rate system side	l/h	5762
Pressure drop system side	kPa	147

(1) Data 14511:2018; System side water heat exchanger 12 °C/7 °C; External air 35 °C

(2) Data 14511:2018; System side water heat exchanger 40 °C/ 45 °C; Outside air 7 °C d.b. / 6 °C w.b.

(3) Data 14511:2018; System side water heat exchanger 23 °C/ 18 °C; External air 35 °C

(4) Data 14511:2018; System side water heat exchanger 30 °C/ 35 °C; Outside air 7 °C d.b. / 6 °C w.b.

ENERGY DATA

Size	Version		101
Cooling capacity with low leaving water temp (UE n° 2016/2281)			
SEER	H	W/W	3,81
	HX,HP	W/W	3,57
η_{sc}	H	%	149,2
	HX,HP	%	139,8
Performance under average climatic conditions (Average) UE n°811/2013 Pdesignh \leq 70kW (1)			
Pdesignh	H		30
	HX		29
	HP		30
SCOP	H		2,73
	HX		3,23
	HP		3,25
η_{sh}	H	%	106
	HX	%	126
	HP	%	127
Efficiency Energy Class	H,HX,HP		A+

(1) Efficiencies for low temperature applications (35°C)

ELECTRIC DATA

Size	Version		101
Electric data (1)			
Maximum current (FLA)	A	H	21,00
Peak current (LRA)	A	H	30,00

(1) Unit standar configuration without hydronic kit

GENERAL TECHNICAL DATA

Size			101
Compressor			
Compressor		type/n°	Scroll/1
Circuit		n°	1
Refrigerant		type	R410A
System side heat exchanger			
Exchanger		type/n°	Plates/1
Connections	(in/out)	\emptyset	1"1/4
Axials fans			
Fans		type/n°	On-Off/2
Air flow rate		m ³ /h	13200
Sound data (1)			
Sound power		dB(A)	76,0
Sound pressure		dB(A)	44,0

(1) Sound power calculated on the basis of measurements made in accordance with UNI EN ISO 9614-2, as required for Eurovent certification. Sound pressure (cold functioning) measured in free field, 10m away from the unit external surface (in compliance with UNI EN ISO 3744).

■ Note: For more information, refer to the selection program or the technical documentation available on the website www.aermec.com

DIMENSIONS

Size	Version		101
Dimensions and weights			
A	all	mm	1450
B	all	mm	1750
C	all	mm	750
Empty weight	H	kg	293
	HX/HP	kg	308

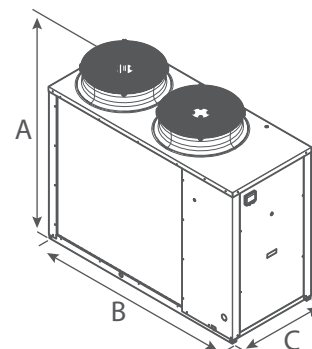

ANLI 101H

Aermec reserves the right to make any modifications deemed necessary. All data is subject to change without notice. Aermec does not assume responsibility or liability for errors or omissions.

Aermec S.p.A.

Via Roma, 996 - 37040 Bevilacqua (VR) - Italia
Tel. 0442633111 - Telefax 044293577
www.aermec.com